

## Application

These valve actuators, with a 50 sq. in. (323 cm<sup>2</sup>) effective diaphragm area, are used for proportional pneumatic control of hot water or chilled water valves.

- MK-66x1 is used to control 1-1/2 in. to 2 in. VB-7xxx series valves.
- MK-68x1 is used to control 2-1/2 in. to 4 in. VB-9xxx series valves
- MK-6811 is used to control 2-1/2 in. to 5 in. VB-8xx3 series valves and 2-1/2 in. to 4 in. VB-9xxx series valves
- MK-6911 is used to control 6 in. VB-8xxx valves

## Features

- Rugged die cast aluminum housing.
- Replaceable beaded molded neoprene diaphragm.
- Built-in spring to retract output shaft.
- Adjustable start point on loss of air pressure.

## Applicable Literature

- TAC Pneumatic Products Catalog, F-27383
- TAC Cross-Reference Guide, F-26789
- TAC Reference Manual, F-21683
- TAC Application Manual, F-21335
- AV-430 Linkage General Instructions, F-19072
- AV-495 Linkage General Instructions, F-21665
- AV-497 Linkage General Instructions, F-27253

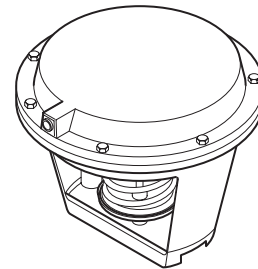

Typical of MK-6600 Series  
and MK-6800 Series

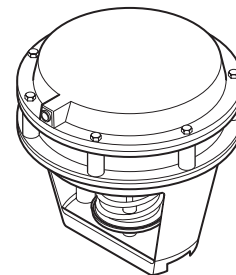

MK-6911

# SPECIFICATIONS

**Construction:**

**Housing,** Die cast aluminum.

**Diaphragm,** Replaceable beaded molded neoprene.

**Stroke:** (Table-1).

**Effective Area:** 50 sq. in. (323 cm<sup>2</sup>).

**Spring:** Retracts actuator shaft and raises valve stem on loss of air pressure.

**Nominal Spring Range:** (Table-1).

**Start Point:** Adjustable  $\pm 2$  psi (14 kPa).

**Maximum Air Pressure:** 30 psig (207 kPa).

**Ambient Temperature Limits:**

**Shipping,** -40 to 220 °F (-40 to 104 °C).

**Operating,** -20 to 220 °F (-29 to 104 °C).

**Air Connections:** 1/8 in. FNPT.

**Valve Linkage:** Order separately (Table-2).

**Locations:** NEMA Type 1 only.

**Mounting:** In any upright position with actuator head above center line of valve body.

**Dimensions:** 7-3/4 H x 10-1/2 W x 10-1/2 D in. (199 x 267 x 267 mm).

**Table-1 Model Chart.**

Model Number	Nominal Spring Range*		Nominal Stroke in. (mm.)	Valve Compatibility		
	psig	kPa		VB-7xxx	VB-8xxx	VB-9xxx
MK-6601	3 to 8	21 to 55	1/2 (13)	1-1/2" to 2" (40 to 50 mm)	—	—
MK-6611	5 to 10	34 to 69			—	
MK-6621	8 to 13	55 to 90			—	
MK-6801	3 to 8	21 to 55	1 (25)	—	—	2-1/2" to 4" (65 to 80 mm)
MK-6811	5 to 10	34 to 69			2-1/2" to 5"	
MK-6821	8 to 13	55 to 90			—	
MK-6911	5 to 10	34 to 69	1-3/4 (44)	—	6"	—

\*Nominal no load spring range based on normal stroke

**Table-2 Valve Linkage.**

Valve Linkage	Valve Body Series
AV-430	VB-7xxx 1-1/2 in. to 2 in. (40 to 50 mm)
AV-495	VB-9xxx 2-1/2 in. to 4 in. (65 to 80 mm)
AV-497	VB-8xxx 2-1/2 in. to 6 in.

**ACCESSORIES**

AK-42309-500 Positive positioner and linkage

TOOL-75 Spring compression tool

TOOL-95 Pneumatic calibration tool kit

**MK-6600 Series**

PNV-245-013 3 to 8 psig green spring

PNV-245-015 5 to 10 psig black spring

PNV-245-018 8 to 13 psig blue spring

**MK-6700 and MK-6800 Series**

PNV-245-103 3 to 8 psig green spring

PNV-245-105 5 to 10 psig black spring

PNV-245-108 8 to 13 psig blue spring

**MK-6900 Series**

PNV-245-145 5 to 10 psig black spring

PNV-245-148 8 to 13 psig blue spring

**All Series**

PNV-202 Diaphragm

# INSTALLATION

## Inspection

Inspect the package for damage. If damaged, notify the appropriate carrier immediately. If undamaged, open the package and inspect the device for obvious damage. Return damaged products.

## Requirements

- Piping diagrams.
- Tools (not provided): Appropriate wrenches for mounting bolts and adjustments.
- Training: Installer must be a qualified, experienced technician or fitter.

### ◆ CAUTION

---

- Make all connections in accordance with the piping diagram.
  - Avoid locations where excessive moisture, corrosive fumes, or vibration are present.
  - The actuator can be mounted in any position above the centerline of the valve body. When selecting a location, allow sufficient room for accessories and for service of the product.
- 

## Mounting

The actuator may be shipped assembled to a valve body or as a separate component. These instructions are intended for use where the actuator is to be installed to a linkage and valve body, as a replacement unit, or when the actuator must be removed during valve installation.

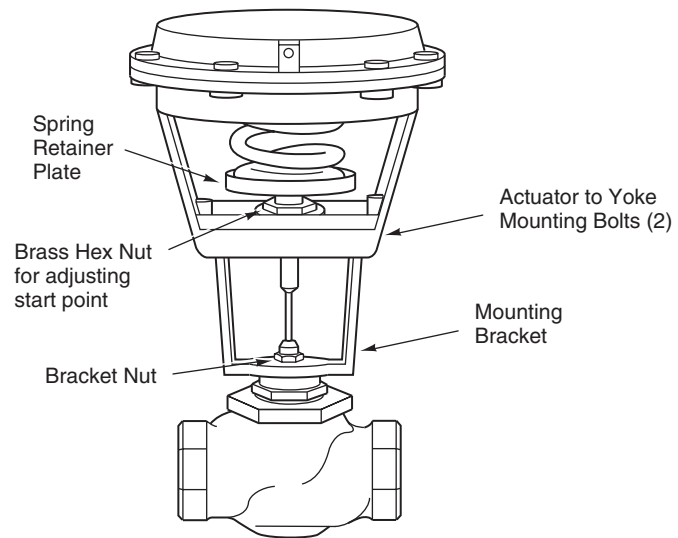

Figure-1 Typical Pneumatic Valve Assembly with MK-6xxx Series Actuator.

## Removing Actuator from Valve Body (Figure-1)

### NOTE

---

It is not necessary to remove the mounting bracket from the valve body in order to service the actuator. If removal of the yoke is required, follow step 3.

---

1. Remove the connecting pin between the actuator piston stem and the valve stem extension. A slight amount of air pressure to the actuator may be necessary to loosen the pin.
2. Remove the two bolts holding the actuator to the yoke, and lift up the actuator.
3. If it is necessary to remove the mounting bracket:

*Current style valves* (valves that do not require removal of packing nut to mount the actuator):

- a. Remove the bracket nut.
- b. Lift the actuator and mounting bracket off the valve body.

*Obsolete style valves* (valves that require removal of packing nut to mount the actuator):

### ⚠ WARNING

---

Any 2-1/2 in. to 6 in. VB-9xxx valve body date coded before 8603 (1986, third week) must have the valve packing nut removed and replaced along with the bracket nut. Before removing the packing nut, isolate the valve body using shutoff valves or depressurize the system to zero gauge and drain the piping. System pressure could cause packing parts to blow out with potential of injury and/or water damage.

---

- a. Remove the packing nut.
- b. Remove the bracket nut.
- c. Lift the actuator and mounting bracket off the valve body.

## Installing Actuator on Valve Body (Figure-1)

If the mounting bracket has been removed, re-install it making certain that the bracket nut is securely tightened. (On obsolete style valves, which require removal of the packing nut to mount the actuator, make certain that the packing nut is tight — tightened four turns.)

1. Place the actuator on the mounting bracket and secure with two bolts. Be sure the air connection is in the proper location.
2. Secure the actuator piston stem to the valve stem extension with the connecting pin. It may be necessary to apply a slight amount of air pressure to the actuator to line up the pin holes.

For additional information, refer to **AV-430 Linkage General Instructions, F-19072, AV-495 Linkage General Instructions F-21665, or AV-497 Linkage General Instructions F-27253.**



## ADJUSTMENTS

The start point adjustment is the only actuator adjustment (Figure-1). The start point is the air pressure which, when applied to the actuator, causes the piston to begin to move downward under a no load condition.

In the course of meeting system requirements or replacing the diaphragm spring, the start point may have been changed. To adjust the start point, proceed as follows (viewing actuator in position shown in Figure-1).

1. Apply desired air pressure to the actuator.
2. Rotate the start point adjustment nut until the desired start point is obtained.

*To raise the start point, rotate the adjustment nut clockwise (CW).*

*To lower the start point, rotate the adjustment nut counterclockwise (CCW).*

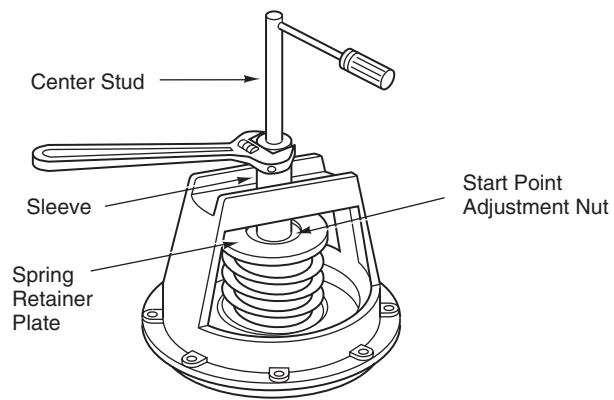

Figure-2 Using Spring Compression Tool.

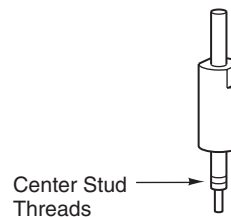

Figure-3 TOOL-75 Spring Compression Tool.

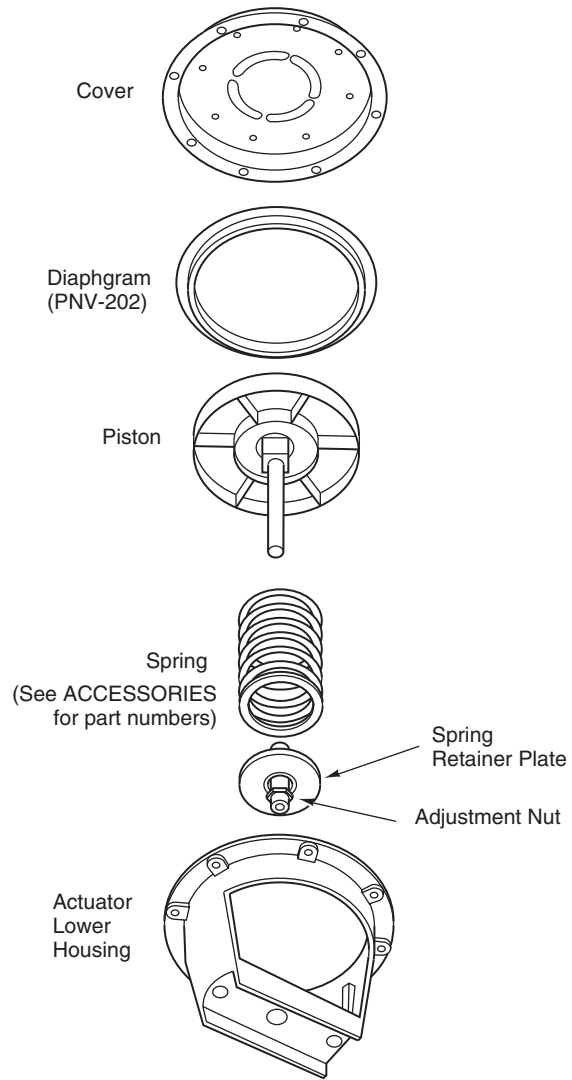

Figure-4 Exploded View of Actuator.

## MAINTENANCE

Regular maintenance of the total system is recommended to assure sustained performance.

## FIELD REPAIR



### Replacing Actuator Diaphragm (Figure-2, Figure-3, and Figure-4)

---

**WARNING**

Strong spring forces are present. Removing the actuator top without securing the spring can result in violent release of spring energy — perhaps resulting in flying parts. Follow the procedure below to prevent possible injury and damage to equipment.

---

1. Remove the actuator from the yoke as explained in the “Installation” section.
2. Place the actuator upside down on the cover top.
3. Thread the center stud of TOOL-75 into the piston stem.
4. Turn the TOOL-75 sleeve down until it rests on the actuator housing.
5. Holding the center stud of TOOL-75 with a small rod or screwdriver to keep it from turning, turn the sleeve clockwise (CW) to compress the actuator spring. When the spring and piston rotate freely within the actuator, the spring is sufficiently compressed to permit removing the actuator cover.
6. Remove the cover screws, cover, and diaphragm.
7. Install the replacement diaphragm and follow the above steps in reverse order.

---

**NOTE**

Be sure that the diaphragm rib fits properly in the actuator cover groove to prevent air from leaking from the diaphragm.

---



### Replacing Actuator Spring (Figure-2, Figure-3, and Figure-4)

---

**WARNING**

Strong spring forces are present. Removing the actuator top without securing the spring can result in violent release of spring energy — perhaps resulting in flying parts. Follow the procedure below to prevent possible injury and damage to equipment.

---

1. Follow the steps outlined for replacing the diaphragm.
2. Place the actuator upside down on the piston top.
3. Holding the center stud of TOOL-75 with a small rod or screwdriver to keep it from turning, turn the sleeve counterclockwise (CCW) to release the spring tension.

---

**NOTE**

The spring can be replaced with an identical spring without changing the start point adjustment. To do this, be sure that the brass start point adjustment nut does not rotate within the spring retainer plate. To make certain the spring range has not been changed, refer to the “Adjustments” section.

---

4. Remove TOOL-75 center stud from the actuator piston stem.
5. Lift the actuator lower housing away from the spring and piston assembly.
6. Lift the adjustment nut and spring retainer plate off the spring.
7. Replace the spring and re-install the parts removed above in the proper order.

---

Copyright 2008, TAC  
All brand names, trademarks and registered  
trademarks are the property of their respective  
owners. Information contained within this  
document is subject to change without notice.

F-13895-12

**TAC**  
1354 Clifford Avenue  
P.O. Box 2940  
Loves Park, IL 61132-2940  
[www.tac.com](http://www.tac.com)

**t.a.c.** <sup>®</sup>  
**by Schneider Electric**